

Lightning Rod kit with Aluminum Tapered Point, Mast Clamp, 8' Ground Rod & clamps, & leg Grounding Lug. Order wire separately below.

LR-8400

#4 Ground Wire, order next longer length from tip of mast to ground rod

CW-2540 25 feet **CW-5040 50 feet**

CW-7540 75 feet **CW-1040 100 feet**

CW-1240 125 feet **CW-1540 150 feet**

GR-5080 5/8 by 8 ft. ground rod weight 8lbs

GR-4400 Ground rod wire clamp weight .5lb

TL-0470 Terminal lug, for wire size to 4 /00



Thrust Bearing premium weatherized twin bearing for rotating setups, 1.3 to 2.6 mast diameter; **TB-25**



Mast Adaptor for non-rotating setups. Secures masts, 1.3 to 2.1 dia. two required, one at tower top and one at base of mast. **MC-10**



Side Arm for adding other antennas, weather gear, etc. 7" high by 1.31" diameter mast, U bolt mounting hardware included.

24" Long # **RA-6024**

48" Long # **RA-6048**

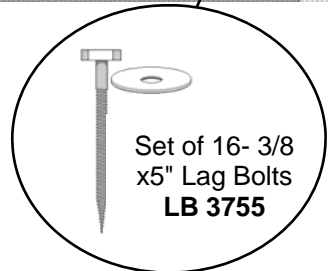
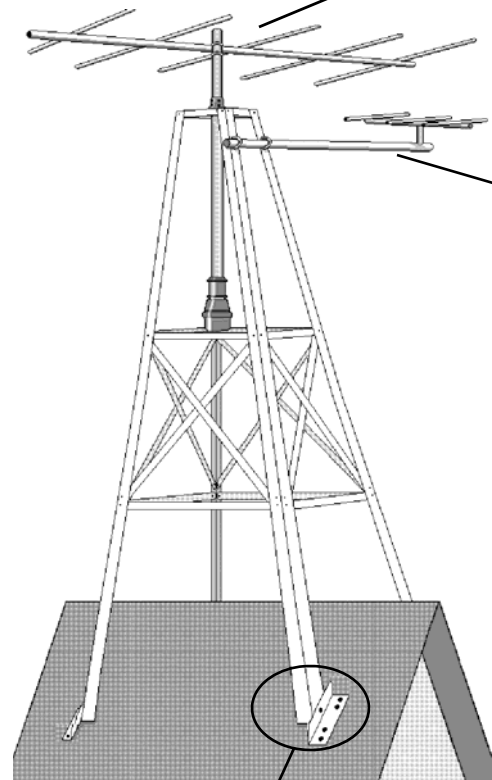
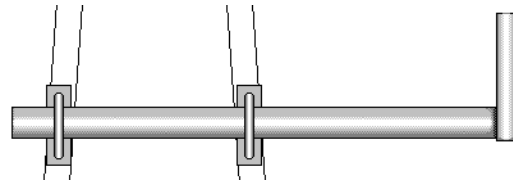

Set of 16- 3/8 x5" Lag Bolts
LB 3755

MASTS Select the mast that matches your needs		
M1049	9' X 1.90" OD X .145 wall galv. steel heavy dty	25 lbs
MA2069	9' X 2.375" OD ,.154 wall aluminum heavy dty	12 lbs
MA1049	9' X 1.90" OD, .145 wall aluminum medium dty	9 lbs
MA5050	5' X 1.315 OD, .133 wall aluminum light duty	3 lbs
MA1050	5' X 1.90 OD, .145 wall aluminum medium duty	5 lbs



GLENMARTIN
Division of TWR Group

Call (800) 486-1223

<http://www.glenmartin.com>

RT-936

OWNER'S MANUAL

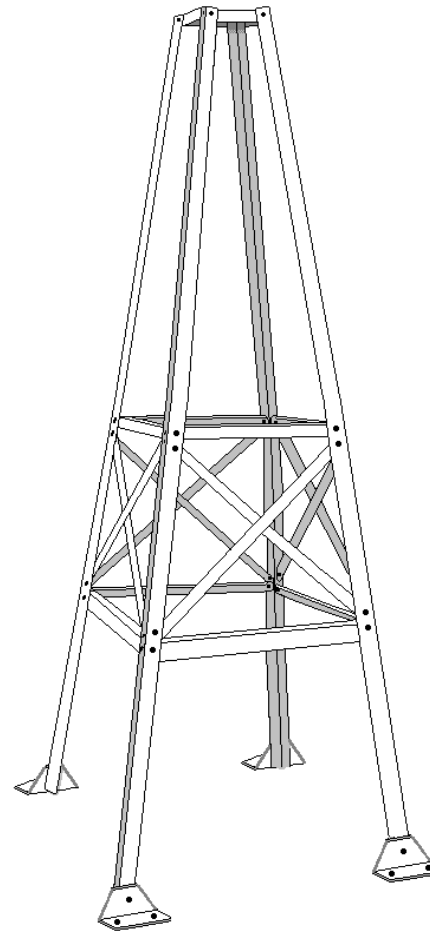

Date Purchased:

CONTENTS	PAGE #
Specifications	2
Shipping carton check list	2
Tools you'll need	4
Assembly	4
Installation	5
Safety Rules	7
GME Warranty	7
Accessories	8



GLENMARTIN
Division of TWR Group

Rev 8/8/11

RT-936 TOWER SPECIFICATIONS

Maximum Height	9 Feet / 2.74 Meters
Maximum Width	36 Inches / 0.91 Meters
Leg Material	6061-T6 Aluminum 1/4"x 2"x 2" Angle
Horizontal brace material	Aluminum, 1/8 X 1-1/2 angle
Diag. Zee brace material	aluminum 1/8 X 1 flat bar
Stainless steel Hardware	14-20 with Nylon self-locking Nuts
Maximum Mast Diameter	2-3/8 Inches / 6 cm
Maximum length of Mast	9 Feet / 2.74 Meters
Max. balanced load weight	120 pounds / 55kg (center balanced)
Mounting bolt size	3/8", 16 required
Rotator Plate	Fits most 4-bolt mounted rotators

Notes to Loading Chart:

- 1) Tower designed in accordance with applicable IBC, AASHTO, and ANSI/TIA-222 standards
- 2) Tower designed with 3-Second gust, exposure C, structure class II, topographic 1
- 3) Max. projected area is the total equipment wind area the tower can support under a specific wind speed
- 4) Roof elevation assumed to be 100 ft. Wind areas in loading chart based on this assumption
- 5) Specific structure study may be required if roof is significant higher than 100 ft and with heavy loading
- 6) Reactions at tower legs and base are factored per ASCE 7's load combinations
- 7) Roof shall be verified to meet specified reactions listed in loading chart before installation

Wind Load Chart

Wind speed (mph)	85	90	95	100	105	110	115	120
Max. projected area (sq.ft)	7.4	6.8	6.2	5.8	5.3	5	4.7	4.3
Down at leg (kip)	1.14	1.18	1.23	1.27	1.33	1.38	1.44	1.50
Uplift at leg (kip)	0.98	1.03	1.09	1.15	1.20	1.27	1.34	1.39
Shear at leg (kip)	0.26	0.27	0.28	0.29	0.31	0.32	0.35	0.36
Shear at base (kip)	0.63	0.68	0.72	0.78	0.83	0.89	0.95	1.01
O.T.M (kip-ft)	4.51	4.69	4.91	5.14	5.36	5.60	5.90	6.12

PARTS LIST

PART #	QTY	DESCRIPTION
1	4	1/4x2x2x108" (.318cm x5cm x5cm) legs
2	4	21 3/4" long lower horizontal braces
3	4	15-1/2" (40 cm) long center horizontal braces
4	2	Rotator support bars
5	4	5" (12.7cm) long top braces
7	8	Flat diagonal braces
8	4	1/4x2x2x5" (.635x5x5x15.25cm) Mounting brackets
9	1	Hardware kit:
	4	3/8 x 1 hex bolts, locking nuts, flat washers –18-8SS
	16	1/4 x 1 hex bolts
	12	1/4 x 3/4 hex bolts
	28	1/4" lock nuts

SAFETY RULES

1. Never mount any tower system close to wires or power lines. Stay at least 1½ times the overall height away from any power lines or wires.
2. Never attempt to touch someone who is in contact with power lines or wires.
3. Never climb the tower. Serious injury could result from a fall. This is even more dangerous when you are on a roof top.
4. If you drop something while working on a roof, never try to catch or stop it. Let it fall and keep your own balance secure.
5. Use the buddy system. Always have someone helping nearby.
6. Always keep children away.
7. **NEVER** attempt to install or attempt to repair equipment while under the influence of drugs, alcohol or any medication.
8. *Certain applications may require field drilling.*

Please keep these instructions in a safe place after installation. If you sell your tower, pass these instructions on to the new owner.

Glenmartin WARRANTY

Glenmartin warrants the RT-936 Roof Tower for 90 days from purchase. If this tower fails to give the original purchaser complete satisfaction within 90 days from the original date of purchase, return it to GlenMartin, Inc. we will repair it, or replace it free of charge. GlenMartin, Inc. will not be liable for loss or damage to property or any incidental or consequential loss or expense from property damage due directly or indirectly from the use of this product.



www.glenmartin.com

2101 West Broadway Blvd Ste. 103 PMB# 241
Columbia, MO 65203
(800) 486-1223

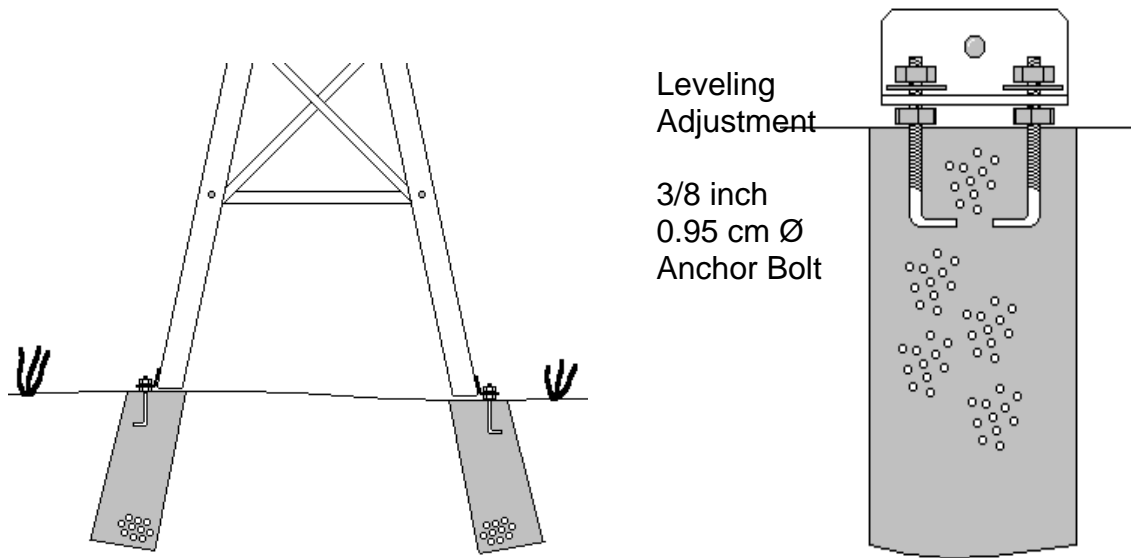

GROUND INSTALLATION RECOMMENDATIONS

1. Place 4 concrete post holes 6" (10-15cm) in diameter 24" (61cm) deep, or AT LEAST 6" (15cm) below the frost line.
2. Use 3/8" (0.95cm) anchor bolts with leveling nuts (order our Part # EL-3744) to secure mounting brackets. Ensure at least 1½" of the threaded portion of the anchor bolt is above the concrete surface.
3. Always install adequate grounding on your tower. (See back page.)

RECOMMENDATIONS ON MOUNTING ANTENNAS

1. Mount rotator.
2. We recommend using a Thrust Bearing to support mast.
3. Use the shortest mast necessary to match installation.
4. Always keep tower, mast & antennas 1½ times the height away from overhead power lines.
5. Adjust rotator, thrust bearing and mast so they are concentric (centered).
6. MC-10 mast adapters are useful if the rotors are mounted at the very top of the mast. In that case two MC-10 are used, one on the rotor plate and one on the thrust bearing plate to secure the mast in place. The mast can not slip downward since it rests on the rotor plate.
7. We **strongly** advise lightning protection for your new tower. Ground your system to achieve a goal of ground resistance of 25 ohms or less. (See our tower accessories on Page 8 of this manual.) When our LR-8400 lightning rod kit is used the lightning rod mounts on the top of the mast and the ground wire attaches to it and continues in one piece all the way to the ground rod.. Measure the length of ground cable you will need and order separately. LR-8400 does not include ground cable.

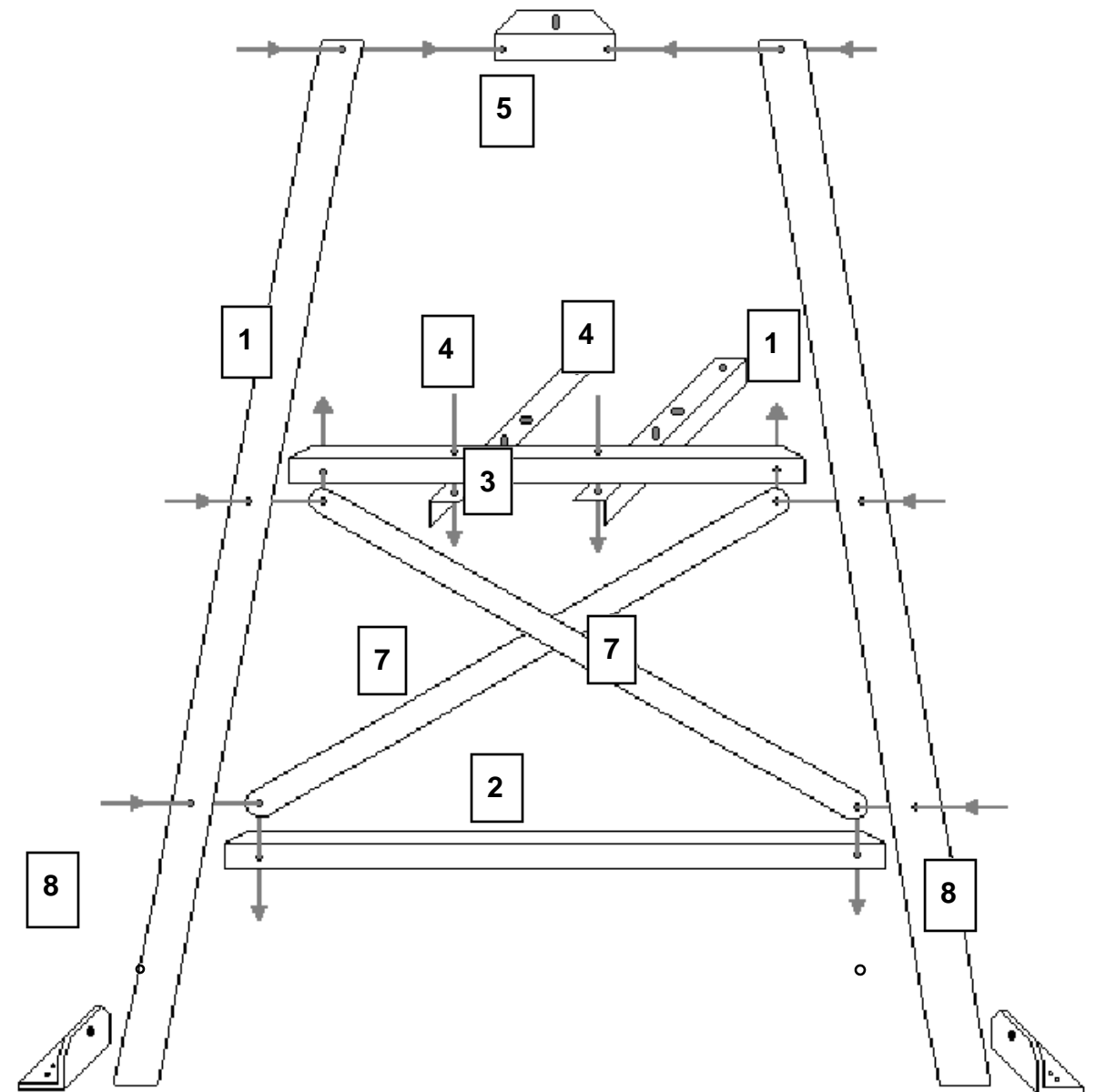

TOOLS YOU'LL NEED FOR ASSEMBLY AND INSTALLATION



SOCKET SET



ADJUSTABLE
END WRENCH

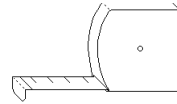

TAPE MEASURE

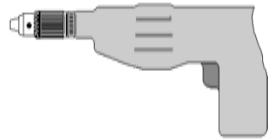

ELECTRIC DRILL

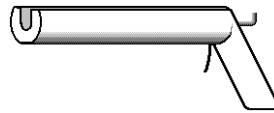

CAULKING GUN

ASSEMBLY

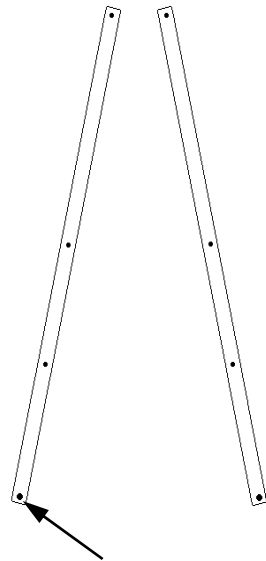

3/8" hole at bottom

1. Lay out two legs (part #1), the two large 3/8" holes are down for attaching to mounting brackets (part #8).
2. Bolt braces #2, 3, and 7 between two legs with 1/4 x 1 stainless steel bolts and nuts. The braces bolt to the inside of leg. Part 7 is sandwiched between part 1 & 2 and part 1 & 3. Part 5 is bolted with 1/4 x 3/4 hex bolts. Mounting brackets (part #8) bolt on the outside of the legs at the bottom with 3/8" bolt, washer, and then nut. They adjust to the roof pitch.
3. Lay out two more legs (part #1) and repeat step 2.
4. This is getting easier now. Join the previously assembled sides with the remaining parts (#2,3,5 and 7) in the same fashion as in step number 2.
5. Mount the rotator support bars (part #4) in place between the part #3 using 1/4 x 3/4 hex bolt. We recommend using the premium, twin-bearing, weatherized thrust bearing, TB-25.
6. Tighten all nuts.
7. Bolt mounting brackets to outside of each leg so base of brackets can match

TYPICAL ROOF INSTALLATION

ATTENTION: Choose a location to mount this tower which is at least 1 1/2 times the height and the overall radius of the antenna away from power lines or overhead wires.

1. These instructions assume a composition shingle roof on wood sheathing and rafters. Use a level across part #3 in both directions to determine plumbness and shim under the mounting bracket if necessary.
2. When possible, it is best to bolt the mounting brackets directly to the center of rafters. If that is not possible, bracing should be added as in the drawing shown below. Two by six boards are added between the rafters and a two by eight is used under the rafters spanning several of them to spread the load.
3. Sealer is applied under & between the shingle flaps, then under the tower mounting brackets.
4. Drill pilot holes for the lag bolts. Fill the pilot holes with silicone before inserting lag bolts.
5. Once lag bolts are tight, caulk heads of bolts and perimeter of mounting brackets with additional silicone.
6. Again use a level to check tower plumbness.

TYPICAL ROOF INSTALLATION PICTURE

